

TR-EX 1500

HYDRAULIC DRILL ATTACHMENT

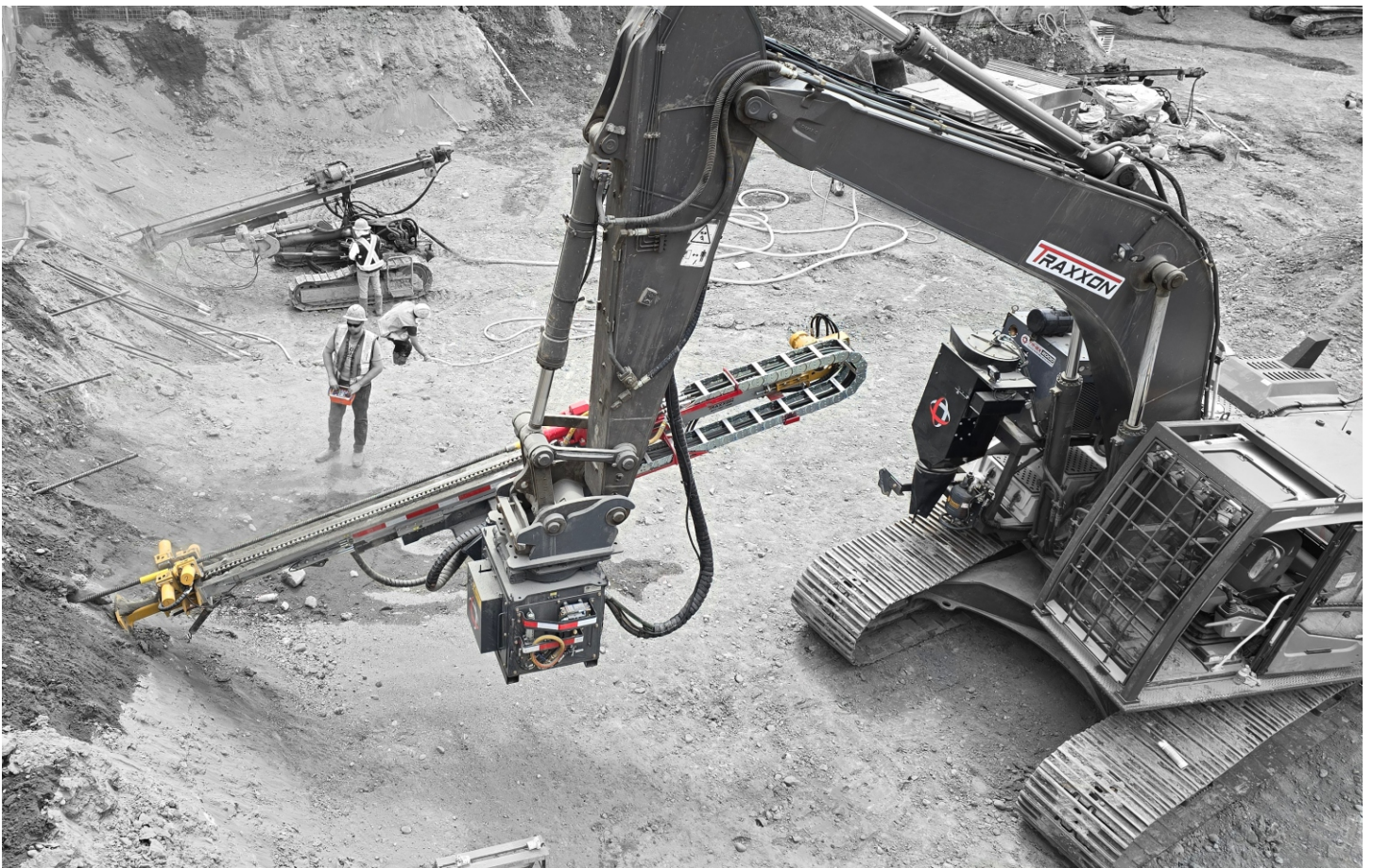

The TR-EX 1500 is a compact and high-performance excavator drill attachment designed for civil engineering works such as anchoring, soil nailing, casing, micropiles, and blast hole drilling.



TR-EX 1500

FEATURES



- Advanced Bosch Rexroth modular electro-hydraulic valvebank.
- In-line high pressure filter to separate contaminants.
- Dual slewing drive feed mast articulation system for various positions.
- Heavy duty modular feed mast with the ability to extend the stroke by adding on a section.
- Radial piston feed motor and extension cylinder with locking valves.
- Dual Axis inclination sensor +/- 30
- Powerful hydraulic drifter with steel energy chain for hose management.
- Integrated flushing swivel on the drifter for air, water flushing, or grout injection.
- Double break-out clamp with optional jaw inserts and ground engagement teeth.
- Utilizes a custom remote control system with proportional functions and a LCD display that reads drilling pressures
- Threading function for easy drill rod alignment.
- Integrated water pressure pump for flushing injection and cleaning of the rig.
- Automated greasing system for critical drifter components.
- Integrated and removable legs for machine storage



TR-EX 1500

SPECIFICATIONS

Excavator Class	16 - 30 ton
Flow Requirement	50 gpm @ 3000 psi (190 l/min)
Feed Mast Stroke	13'-6"
Feed / Retract Force	7,000 lbs
Clamp Range	1.25" - 5"
Clamping Force	30,000 lbs
Breaking Torque	14,000 lb*ft
Rotation Range	Dual Axis 360°
Inclinometer Range	+/- 30° from Horizontal or Vertical
Hydraulic Drifter	See specification sheet
Weight	5,000 lbs

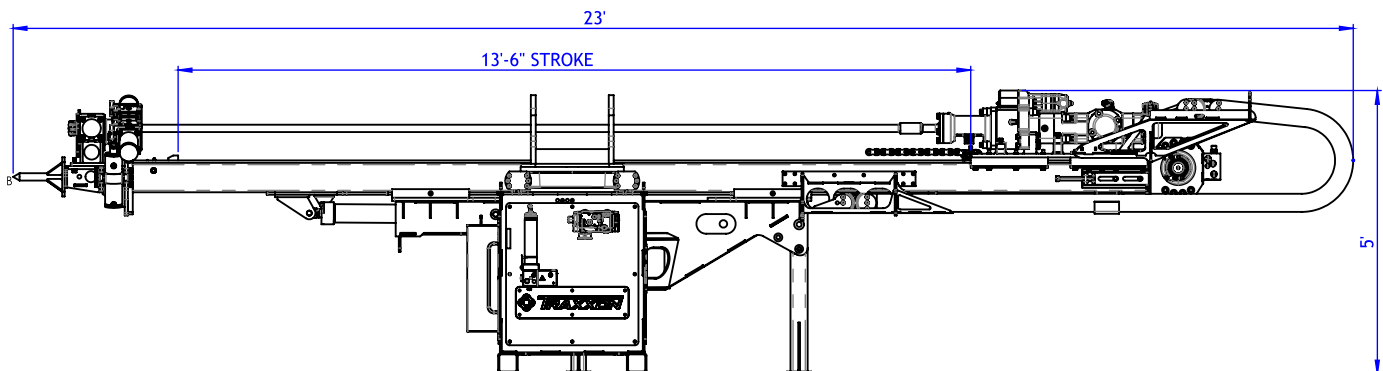
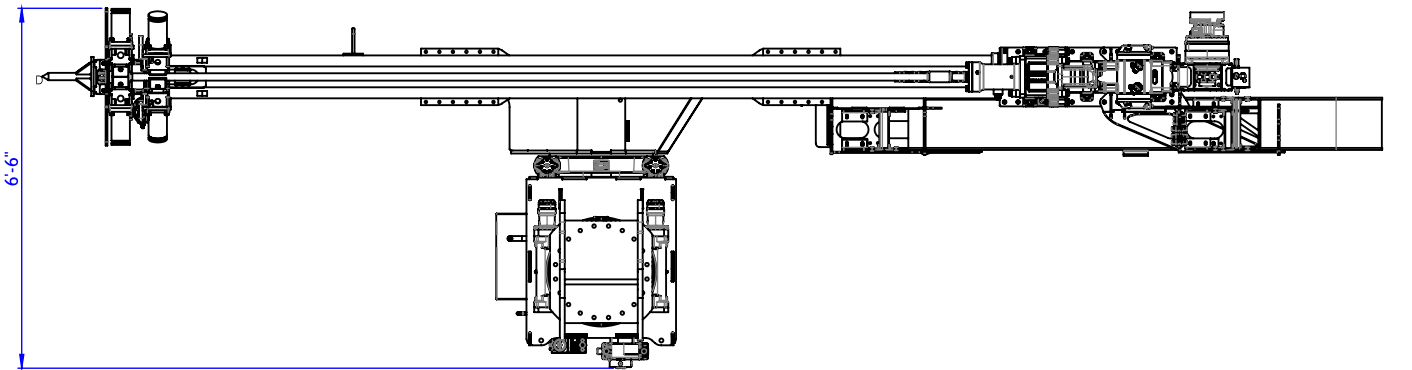
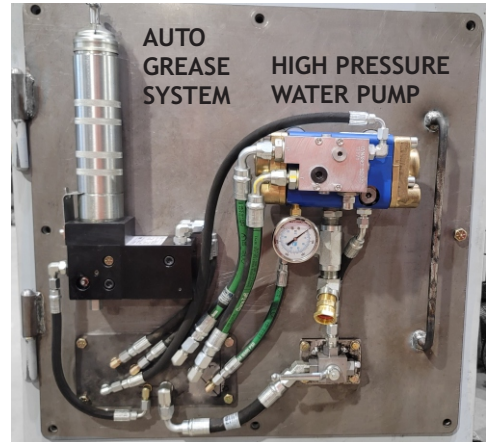

TX690sr

HYDRAULIC DRIFTER SPECIFICATIONS

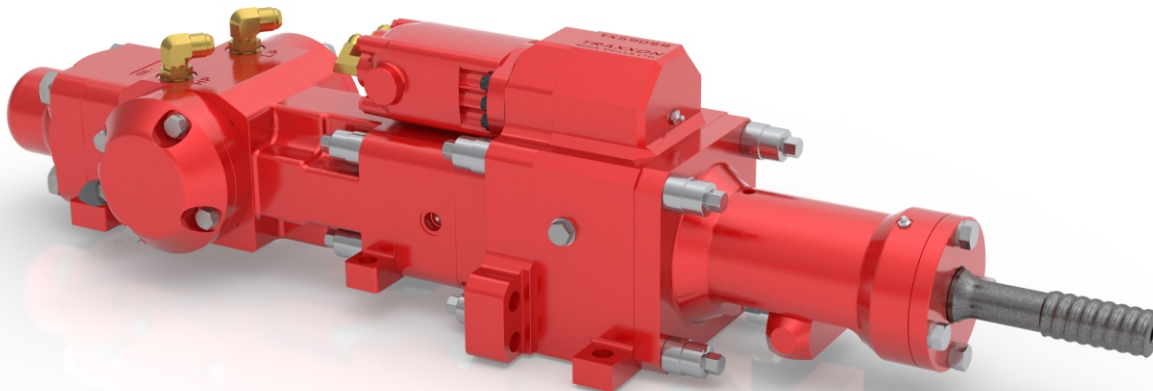

FEATURES and SPECIFICATIONS:

- Separate and easily removable flushing swivel allows the use of high pressure air, grout, or water and eliminates the possibility of back-flushing contaminants into the hammer body.
- Built in swivel shortens the drill string, as compared to separate drill and swivel designs.
- Sealed and grease lubricated rotation housing.
- Utilizes proven Sandvik HL700 drifter shanks and accumulator diaphragms.

HOLE SIZE:	64 - 102 mm, 2.5 - 4 in
SHANK ADAPTERS:	T38, T45, T51
IMPACT FREQUENCY:	44 - 56 Hz
POWER CLASS:	18 kW
OPERATING PRESSURE:	120 - 170 bar
SHANK LUBRICATION:	Grease, Air / Oil
FLUSHING:	Air, Water, Grout
WEIGHT:	235 kg, 520 lbs

Rotation Motor Size	MAX Output Torque @ 2500 psi	MAX RPM with 16 gpm Hydraulic Flow
130cc	500 ft/lbs	230 rpm
160cc	558 ft/lbs	187 rpm
195cc	688 ft/lbs	154 rpm
245cc	860 ft/lbs	122 rpm
305cc	950 ft/lbs	98 rpm